



www.FGWilson.com

# S320P1/S350E1



Image for illustration purposes only.

## Output Ratings

Generating Set Model	Prime*	Standby*
-	- / -	- / -
440/254V, 60Hz	320.0 kVA / 256.0 kW	350.0 kVA / 280.0 kW

Ratings at 0.8 power factor.

### Prime Rating

These ratings are applicable for supplying continuous electrical power (at variable load) in lieu of commercially purchased power. There is no limitation to the annual hours of operation and this model can supply 10% overload power for 1 hour in 12 hours.

### Standby Rating

These ratings are applicable for supplying continuous electrical power (at variable load) in the event of a utility power failure. No overload is permitted on these ratings. The alternator on this model is peak continuous rated (as defined in ISO 8528-3).

### Standard Reference Conditions

Note: Standard reference conditions 25°C (77°F) Air Inlet Temp, 100m (328 ft) A.S.L. 30% relative humidity.  
Fuel consumption data at full load with diesel fuel with specific gravity of 0.85 and conforming to BS2869: 1998, Class A2.

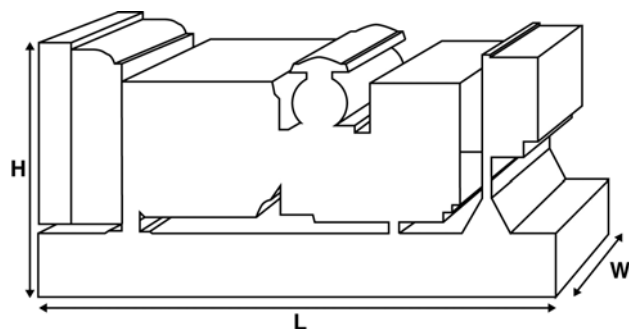

## Ratings and Performance Data

Engine Make & Model:	Scania DC9 65A 10-95	
Alternator manufactured for FG Wilson by:	WEG	
Alternator Model:	GTA311 AIVS	
Control Panel:	PowerWizard 1.0	
Base Frame:	Heavy Duty Fabricated Steel	
Circuit Breaker Type:	3 Pole MCCB	
Frequency:	50 Hz	60 Hz
Engine Speed: RPM	-	1800
Fuel Tank Capacity: litres (US gal)	250 (66.0)	
Fuel Consumption: l/hr (US gal/hr) (100% Load)	- Prime	67.7 (17.9)
	- Standby	70.8 (18.7)

## Available Options

FG Wilson offer a range of optional features to tailor our generating sets to meet your power needs. Options include:

- A wide range of Sound Attenuated Enclosures
- A variety of generating set control and synchronising panels
- Additional alarms and shutdowns
- A selection of exhaust silencer noise levels

For further information on all of the standard and optional features accompanying this product please contact your local Dealer or visit: [www.FGWilson.com](http://www.FGWilson.com)

## Dimensions and Weights

Length (L) mm (in)	Width (W) mm (in)	Height (H) mm (in)	Dry kg (lb)	Wet kg (lb)
3375 (132.9)	1120 (44.1)	1935 (76.2)	2787 (6144)	2840 (6261)
Dry = With Lube Oil		Wet = With Lube Oil and Coolant		

Ratings in accordance with ISO 8528, ISO 3046, IEC 60034, BS5000 and NEMA MG-1/22. Generating set pictured may include optional accessories.

**FG Wilson has manufacturing facilities in the following locations:**

Northern Ireland • Brazil • China • India • USA

With headquarters in Northern Ireland, FG Wilson operates through a Global Dealer Network.

To contact your local Sales Office please visit the FG Wilson website at [www.FGWilson.com](http://www.FGWilson.com)

Engine Technical Data	
No. of Cylinders / Alignment:	5 / In Line
Cycle:	4 Stroke
Bore / Stroke: mm (in)	127.0 (5.0)/140.0 (5.5)
Induction:	Turbocharged Air To Air Charge Cooled
Cooling Method:	Water
Governing Type:	Electronic
Governing Class:	ISO 8528 G2
Compression Ratio:	18.1
Displacement: l (cu. in)	8.9 (543.1)
Moment of Inertia: kg m <sup>2</sup> (lb/in <sup>2</sup> )	2.74 (9363)
Engine Electrical System:	
- Voltage / Ground	24/Negative
- Battery Charger Amps	100
Weight: kg (lb)	
- Dry	887 (1955)
- Wet	940 (2072)

Performance	50 Hz	60 Hz
Engine Speed: rpm	-	1800
Gross Engine Power: kW (hp)		
- Prime	-	294.0 (394.0)
- Standby	-	315.0 (422.0)
BMEP: kPa (psi)		
- Prime	-	2210.0 (320.6)
- Standby	-	2368.0 (343.5)

Fuel System				
Fuel Filter Type:	Replaceable Element			
Recommended Fuel:	Diesel			
Fuel Consumption: l/hr (US gal/hr)				
	110%	100%	75%	50%
Prime	Load	Load	Load	Load
50 Hz	-	-	-	-
60 Hz	70.8 (18.7)	67.7 (17.9)	54.9 (14.5)	35.8 (9.5)
	110%	100%	75%	50%
Standby	Load	Load	Load	Load
50 Hz	-	-	-	-
60 Hz	70.8 (18.7)	59.0 (15.6)	39.7 (10.5)	

(Based on diesel fuel with a specific gravity of 0.84 and conforming to BS2869, Class A2)

Air Systems	50 Hz	60 Hz
Air Filter Type:	Replaceable Element	
Combustion Air Flow: m <sup>3</sup> /min (cfm)		
- Prime	-	20.2 (715)
- Standby	-	21.1 (745)
Max. Combustion Air Intake Restriction: kPa (in H <sub>2</sub> O)	-	4.9 (19.7)

Cooling System	50 Hz	60 Hz
Cooling System Capacity: l (US gal)	-	57.0 (15.1)
Water Pump Type:	Centrifugal	
Heat Rejected to Water & Lube Oil:		
kW (Btu/min)		
- Prime	-	114.0 (6483)
- Standby	-	120.0 (6824)
Heat Radiation to Room: Heat radiated from engine		
kW (Btu/min)		
- Prime	-	30.0 (1706)
- Standby	-	31.0 (1763)
Radiator Fan Load: kW (hp)	-	11.0 (14.8)
Radiator Cooling Airflow: m <sup>3</sup> /min (cfm)	-	450.0 (15892)
External Restriction to Cooling Airflow: Pa (in H <sub>2</sub> O)	-	196 (0.8)

Contact your local FG Wilson Dealer for power ratings at specific site conditions.

Lubrication System	
Oil Filter Type:	Spin-On, Full Flow
Total Oil Capacity: l (US gal)	37.0 (9.8)
Oil Pan: l (US gal)	29.0 (7.7)
Oil Type:	API CE or CF
Oil Cooling Method:	Water

Exhaust System	50 Hz	60 Hz
Silencer Type:	Level 1	
Silencer Model & Quantity:	SD125 (1)	
Pressure Drop Across Silencer System: kPa (in Hg)	-	0.20 (0.059)
Silencer Noise Reduction Level: dB	-	10
Maximum Allowable Back Pressure: kPa (in Hg)	-	5.9 (1.7)
Exhaust Gas Flow: m <sup>3</sup> /min (cfm)		
- Prime	-	53.0 (1872)
- Standby	-	55.0 (1942)
Exhaust Gas Temperature: °C (°F)		
- Prime	-	533 (991)
- Standby	-	539 (1002)

Alternator Physical Data	
Manufactured for FG Wilson by:	WEG
Model:	GTA311 AIVS
No. of Bearings:	1
Insulation Class:	H
Winding Pitch Code:	2/3 - -
Wires:	12
Ingress Protection Rating:	IP21
Excitation System:	BRUSHLESS
AVR Model:	GRT7-TH4E

Alternator Operating Data	
Overspeed: rpm	2250
Voltage Regulation: (Steady state)	+/- 0.5
Wave Form NEMA = TIF:	50
Wave Form IEC = THF:	2.0%
Total Harmonic content LL/LN:	5.0%
Radio Interference:	Suppression is in line with European Standard EN61000-6
Radiant Heat: kW (Btu/min)	
- 50 Hz	-
- 60 Hz	26.2 (1490)

Alternator Performance Data:	50 Hz	60 Hz
Data Item		380/220V 440/254V 220/127V
Motor Starting Capability* kVA		107 143
Short Circuit Capacity %		300 300
Reactances: Per Unit		
Xd		5.000 3.730
X'd		0.380 0.290
X''d		0.278 0.207

Reactances shown are applicable to prime ratings.  
\*Based on 30% voltage dip at 0.6 power factor.

Voltage Technical Data 50 Hz				
Voltage	Prime:		Standby:	
	kVA	kW	kVA	kW

Voltage Technical Data 60 Hz				
Voltage	Prime:		Standby:	
	kVA	kW	kVA	kW
220/127V	320.0	256.0	350.0	280.0
380/220V	320.0	256.0	344.0	275.2
440/254V	320.0	256.0	350.0	280.0

**Documentation**

A full set of operation and maintenance manuals and circuit wiring diagrams.

**Generating Set Standards**

The equipment meets the following standards: BS5000, ISO 8528, ISO 3046, IEC 60034, NEMA MG-1.22.

FG Wilson is a fully accredited ISO 9001 company.

**Warranty**

All prime equipment carries a one year manufacturer's warranty. Standby equipment, limited to 500 running hours per year, has a two year manufacturer's warranty. For details on warranty cover please contact your local Dealer, or visit our website: [FGWilson.com](http://FGWilson.com).

**Dealer contact details:**

**FG Wilson has manufacturing facilities in the following locations:**

Northern Ireland • Brazil • China • India • USA

With headquarters in Northern Ireland, FG Wilson operates through a Global Dealer Network.

To contact your local Sales Office please visit the FG Wilson website at [www.FGWilson.com](http://www.FGWilson.com)