



www.FGWilson.com

# UG11P1S/UG13E1S



## Output Ratings

Generating Set Model	UG11P1S/UG13E1S	
LPG	Prime	Standby
220 – 240V, 50 Hz	11.0 kVA / 11.0 kW	13.0 kVA / 13.0 kW
240/120V, 60 Hz	13.5 kVA / 13.5 kW	15.9 kVA / 15.9 kW
Natural Gas		
220 – 240V, 50 Hz	10.0 kVA / 10.0 kW	11.8 kVA / 11.8 kW
240/120V, 60 Hz	13.0 kVA / 13.0 kW	15.0 kVA / 15.0 kW

Ratings at 1.0 pf

## Definitions

### Standby Rating

These ratings are applicable for supplying continuous electrical power (at variable load) in the event of a utility power failure. No overload is permitted on these ratings. The alternator on this model is peak continuous rated (as defined in ISO 8528-3).

### Prime Rating

These ratings are applicable for supplying continuous electrical power (at variable load) in lieu of commercially purchased power. There is no limitation to the annual hours of operation and this model can supply 10% overload power for 1 hour in 12 hours.

### Standard Reference Conditions

Ratings in accordance with ISO 8528. All engine performance data based on the above mentioned maximum continuous ratings. Fuel Consumption data assumes complete combustion of LPG fuel with a calorific value of 95MJ/m<sup>3</sup> and of Natural gas with a calorific value of 34.4MJ/m<sup>3</sup>.

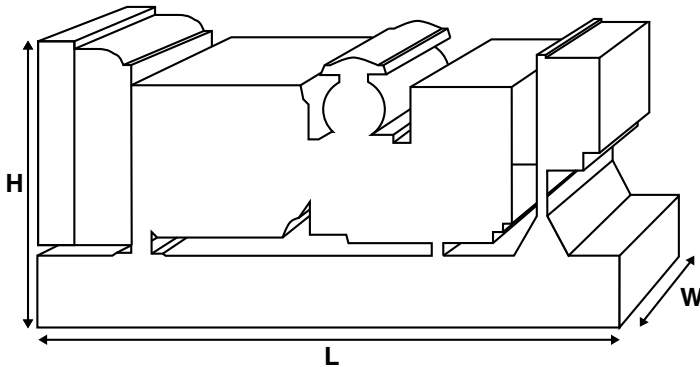

## Ratings and Performance Data

Engine Make and Model	HM 1.8L	
Alternator manufacturer for FG Wilson by:	Leroy Somer	
Alternator Model:	LUB1014NX	
Control Panel:	PowerWizard 1.0	
Base Frame:	Heavy Duty Fabricated Steel	
Circuit Breaker Type/Rating:	3 Pole MCCB	
Frequency:	50 Hz	60 Hz
Engine Speed: RPM:	1500	1800
Fuel Consumption, LPG: m <sup>3</sup> /hr (ft <sup>3</sup> /hr)		
	– Prime: 1.8 (63.6)	2.2 (77.7)
	– Standby: 2.2 (77.7)	2.6 (91.8)
Natural Gas: m <sup>3</sup> /hr (ft <sup>3</sup> /hr)		
	– Prime: 4.3 (151.9)	5.5 (194.2)
	– Standby: 5.1 (180.1)	6.4 (226.0)

## Available Options

FG Wilson offer a range of optional features to tailor our generating sets to meet your power needs. Options include:

- Upgrade to CE Certification
- A wide range of Sound Attenuated Containers
- A variety of generating set control and synchronising panels
- Additional alarms and shutdowns
- A selection of exhaust silencer noise levels

For further information on all of the standard and optional features accompanying this product please contact your local Dealer or visit: [www.FGWilson.com](http://www.FGWilson.com)

## Dimensions and Weights

Length (L) mm (in)	Width (W) mm (in)	Height (H) mm (in)	Dry kg (lb)	Wet kg (lb)
1350 (53.1)	715 (28.1)	1004 (39.5)	393 (866)	405 (893)

Dry = With Lube Oil Wet = With Lube Oil and Coolant

Ratings in accordance with ISO 8528, ISO 3046, IEC 60034, BS5000 and NEMA MG-1/22. Generating set pictured may include optional accessories.

## FG Wilson has manufacturing facilities in the following locations:

Northern Ireland • Brazil • China • India • USA

With headquarters in Northern Ireland, FG Wilson operates through a Global Dealer Network. To contact your local Sales Office please visit the FG Wilson website at [www.FGWilson.com](http://www.FGWilson.com)

Engine Technical Data	
No. of Cylinders/Alignment:	4 in Line
Cycle:	4 Stroke
Bore/Stroke: mm (in)	84.0 (3.3) / 82.0 (3.2)
Induction:	Naturally Aspirated
Cooling Method:	Water
Governing Type:	Electronic
Governing Class:	ISO 8528 G2
Compression Ratio:	8.5:1
Displacement: l (cu.in):	1.8 (111.1)
Engine Electrical System:	
-Voltage/Ground	12/Negative
-Battery Charger Amps	45
Weight (includes lube oil): kg (lb)	143 (315)

Performance	50 Hz	60 Hz
Engine Speed: rpm	1500	1800
Gross Engine Power: kW (hp)		
- Standby:	15.7 (21)	19.5 (26)
- Prime:	13.4 (18)	16.6 (22)
BMEP: kPa (psi)		
- Standby:	691 (100.2)	715 (103.7)
- Prime:	590 (85.5)	609 (88.3)

Fuel Systems					
Fuel Filter Type:	Replaceable Element				
Permitted Fuel:	LPG / Natural Gas				
Fuel Consumption LPG: m <sup>3</sup> /hr (cfh)					
	110%	100%	75%	50%	
Prime	Load	Load	Load	Load	
50 Hz	2.2 (77.7)	1.8 (63.6)	1.4 (49.4)	1.0 (35.3)	
60 Hz	2.6 (91.8)	2.2 (77.7)	1.7 (60.0)	1.2 (42.4)	
Standby					
50 Hz	-	2.2 (77.7)	1.6 (56.5)	1.1 (38.8)	
60 Hz	-	2.6 (91.8)	2.0 (70.6)	1.3 (45.9)	
Fuel Consumption Natural Gas: m <sup>3</sup> /hr (cfh)					
	110%	100%	75%	50%	
Prime	Load	Load	Load	Load	
50 Hz	5.1 (180.1)	4.3 (151.9)	3.3 (116.5)	2.2 (77.7)	
60 Hz	6.4 (226.0)	5.5 (194.2)	4.1 (144.8)	2.9 (102.4)	
Standby					
50 Hz	-	5.1 (180.1)	3.8 (134.2)	2.6 (91.8)	
60 Hz	-	6.4 (226.0)	4.8 (169.5)	3.3 (116.5)	

Air Systems	50 Hz	60 Hz
Combustion Air Flow LPG: m <sup>3</sup> /min (cfm)		
- Standby:	1.3 (46)	1.6 (57)
- Prime:	1.1 (39)	1.6 (57)
Combustion Air Flow Natural Gas:		
m <sup>3</sup> /min (cfm)		
- Standby:	1.1 (39)	1.5 (53)
- Prime:	1.0 (35)	1.3 (46)
Max. Combustion Air Intake		
Restriction: kPa (in H <sub>2</sub> O)	1.5 (6)	1.5 (6)
Radiator Cooling Airflow: m <sup>3</sup> /min (cfm)	63 (2225)	75.6 (2670)
External Restriction to Cooling Airflow:		
kPa (in H <sub>2</sub> O)	247 (0.99)	247 (0.99)

Cooling System	50 Hz	60 Hz
Cooling System Capacity: l (US gal)	6.1 (1.6)	6.1 (1.6)
Water Pump Type:	Centrifugal	
Heat Rejected to Water &		
Lube Oil: kW (Btu/min)		
- Standby:	13.9 (792)	17.1 (970)
- Prime:	11.9 (674)	14.5 (826)
Heat Radiation to Room: kW (Btu/min)		
- Standby:	7.4 (418)	9.0 (512)
- Prime:	6.3 (355)	7.7 (436)
Radiator Fan Load:	0.52 (0.7)	0.90 (1.21)

Lubrication System	50 Hz	60 Hz
Oil Filter Type:	Spin-On, Full Flow	
Total Oil Capacity: l (US gal)	4.5 (1.2)	
Oil Pan: l (US gal)	4.0 (1.1)	
Oil Type:	API CF4 15W-40	
Oil Cooling Method:	Water	

Exhaust System	50 Hz	60 Hz
Max. Allowable Back Pressure: kPa (in Hg)	17.3 (5.1)	17.3 (5.1)
Exhaust Gas Flow LPG: m <sup>3</sup> /min (cfm)		
- Standby:	3.87 (137)	4.83 (171)
- Prime:	3.23 (114)	4.00 (141)
Natural Gas: m <sup>3</sup> /min (cfm)		
- Standby:	3.57 (126)	4.89 (173)
- Prime:	2.90 (102)	4.36 (154)
Exhaust Gas Temperature LPG: °C (°F):		
- Standby:	568 (1054)	600 (1112)
- Prime:	552 (1026)	584 (1083)
Natural Gas °C (°F):		
- Standby:	580 (1076)	612 (1134)
- Prime:	557 (1035)	605 (1121)

### Alternator Physical Data

Manufactured for FG Wilson by:	Leroy Somer
Model:	LUB1014NX
No. of Bearings:	Single
Insulation Class:	H
Winding Pitch Code:	2/3 (M)
Wires:	4
Ingress Protection Rating:	IP23
Excitation System:	SHUNT
AVR Model:	R250

### Alternator Operating Data

Overspeed: RPM	2250
Voltage Regulation (steady state):	+/- 1%
Wave Form NEMA = TIF:	<50
Wave Form IEC = THF:	<2%
Total Harmonic Content LL/LN:	<4.0%
Radio Interference:	Suppression is in line with European Standard EN61000-6
Radiant Heat: kW (Btu/min)	50 Hz: 1.9 (108) 60 Hz: 2.4 (136)

### Alternator Performance Data:

Data Item	50 Hz			60 Hz	
	220	230	240	220/110	240/120
Motor Starting Capability* kVA	29	31	33	25	29
Reactances: Per Unit					
<b>X<sub>d</sub></b>	1.19	1.09	1.00	1.76	1.48
<b>X'<sub>d</sub></b>	0.16	0.15	0.13	0.23	0.20
<b>X''<sub>d</sub></b>	0.075	0.069	0.063	0.110	0.093

Reactances shown are applicable to prime ratings using LPG fuel

\* Based on 30% voltage dip at 0.9 power factor and shunt excitation system

### Voltage Technical Data

	50 Hz				60 Hz				
	UG11P1S Prime		UG13E1S Standby		UG11P1S Prime		UG13E1S Standby		
	kVA	kW	kVA	kW	kVA	kW	kVA	kW	
240	11.0	11.0	13.0	13.0	240/120	13.5	13.5	16.0	16.0
230	11.0	11.0	13.0	13.0	220/110	13.5	13.5	15.9	15.9
220	11.0	11.0	13.0	13.0					

These ratings are based on generating set performance using LPG fuel.

### Voltage Technical Data

	50 Hz				60 Hz				
	UG11P1S Prime		UG13E1S Standby		UG11P1S Prime		UG13E1S Standby		
	kVA	kW	kVA	kW	kVA	kW	kVA	kW	
240	10.0	10.0	11.8	11.8	240/120	13.0	13.0	15.0	15.0
230	10.0	10.0	11.8	11.8	220/110	13.0	13.0	15.0	15.0
220	10.0	10.0	11.8	11.8					

These ratings are based on generating set performance using Natural Gas fuel.

## General Information

### Documentation

A full set of operation and maintenance manuals and circuit wiring diagrams.

### Generating Set Standards

The equipment meets the following standards: BS5000, ISO 8528, ISO 3046, IEC 60034, NEMA MG-1.22.  
FG Wilson is a fully accredited ISO 9001 company.

### Warranty

All equipment carries full manufacturer's warranty. Extended warranty terms available. For details on warranty cover please contact your local dealer, or visit our website: [www.FGWilson.com](http://www.FGWilson.com)

### Dealer Contact Details:

### FG Wilson has manufacturing facilities in the following locations:

Northern Ireland • Brazil • China • India • USA

With headquarters in Northern Ireland, FG Wilson operates through a Global Dealer Network.  
To contact your local Sales Office please visit the FG Wilson website at [www.FGWilson.com](http://www.FGWilson.com)