



www.FGWilson.com

P16.5-4S



Image for illustration purposes only.

Output Ratings

Generating Set Model	Prime*	Standby*
220-240V, 50 Hz	15.0 kVA / 15.0 kW	16.5 kVA / 16.5 kW
240/120V, 60 Hz	18.0 kVA / 18.0 kW	20.0 kVA / 20.0 kW

Ratings at 1.0 power factor.

Prime Rating

These ratings are applicable for supplying continuous electrical power (at variable load) in lieu of commercially purchased power. There is no limitation to the annual hours of operation and this model can supply 10% overload power for 1 hour in 12 hours.

Standby Rating

These ratings are applicable for supplying continuous electrical power (at variable load) in the event of a utility power failure. No overload is permitted on these ratings. The alternator on this model is peak continuous rated (as defined in ISO 8528-3).

Standard Reference Conditions

Note: Standard reference conditions 25°C (77°F) Air Inlet Temp, 100m (328 ft) A.S.L. 30% relative humidity.
Fuel consumption data at full load with diesel fuel with specific gravity of 0.85 and conforming to BS2869: 1998, Class A2.

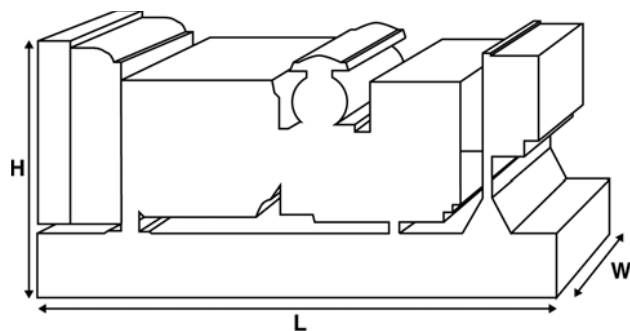

Ratings and Performance Data

Engine Make & Model:	Perkins 404D-22G	
Alternator manufactured for FG Wilson by:	Leroy Somer	
Alternator Model:	LLB1014N	
Control Panel:	LCP1002T	
Base Frame:	Heavy Duty Fabricated Steel	
Circuit Breaker Type:	3 Pole MCB	
Frequency:	50 Hz	60 Hz
Engine Speed: RPM	1500	1800
Fuel Tank Capacity: litres (US gal)	45 (11.9)	
Fuel Consumption: l/hr (US gal/hr) (100% Load)	- Prime	4.9 (1.3) 5.9 (1.6)
	- Standby	5.5 (1.5) 6.6 (1.7)

Available Options

FG Wilson offer a range of optional features to tailor our generating sets to meet your power needs. Options include:

- Upgrade to CE Certification
- A wide range of Sound Attenuated Enclosures
- A variety of generating set control and synchronising panels
- Additional alarms and shutdowns
- A selection of exhaust silencer noise levels

For further information on all of the standard and optional features accompanying this product please contact your local Dealer or visit: www.FGWilson.com

Dimensions and Weights

Length (L) mm (in)	Width (W) mm (in)	Height (H) mm (in)	Dry kg (lb)	Wet kg (lb)
1320 (52.0)	552 (21.7)	1179 (46.4)	460 (1014)	467 (1030)
Dry = With Lube Oil		Wet = With Lube Oil and Coolant		

Ratings in accordance with ISO 8528, ISO 3046, IEC 60034, BS5000 and NEMA MG-1/22. Generating set pictured may include optional accessories.

FG Wilson has manufacturing facilities in the following locations:

Northern Ireland • Brazil • China • India • USA

With headquarters in Northern Ireland, FG Wilson operates through a Global Dealer Network.

To contact your local Sales Office please visit the FG Wilson website at www.FGWilson.com

Engine Technical Data	
No. of Cylinders / Alignment:	4 / In Line
Cycle:	4 Stroke
Bore / Stroke: mm (in)	84.0 (3.3)/100.0 (3.9)
Induction:	Naturally Aspirated
Cooling Method:	Water
Governing Type:	Mechanical
Governing Class:	ISO 8528 G2
Compression Ratio:	23.3:1
Displacement: l (cu. in)	2.2 (135.2)
Moment of Inertia: kg m ² (lb/in ²)	2.72 (9308)
Engine Electrical System:	
- Voltage / Ground	12/Negative
- Battery Charger Amps	65
Weight: kg (lb)	
- Dry	242 (534)
- Wet	251 (554)

Performance	50 Hz	60 Hz
Engine Speed: rpm	1500	1800
Gross Engine Power: kW (hp)		
- Prime	18.7 (25.0)	22.0 (30.0)
- Standby	20.6 (28.0)	24.3 (33.0)
BMEP: kPa (psi)		
- Prime	675.0 (97.9)	662.0 (96.0)
- Standby	743.0 (107.8)	731.0 (106.0)

Fuel System					
Fuel Filter Type:	Replaceable Element				
Recommended Fuel:	Class A2 Diesel				
Fuel Consumption: l/hr (US gal/hr)					
	110%	100%	75%	50%	
Prime	Load	Load	Load	Load	
50 Hz	5.5 (1.5)	4.9 (1.3)	3.7 (1.0)	2.7 (0.7)	
60 Hz	6.6 (1.7)	5.9 (1.6)	4.5 (1.2)	3.3 (0.9)	
	110%	100%	75%	50%	
Standby	Load	Load	Load	Load	
50 Hz		5.5 (1.5)	4.0 (1.1)	2.9 (0.8)	
60 Hz		6.6 (1.7)	4.9 (1.3)	3.6 (1.0)	

(Based on diesel fuel with a specific gravity of 0.84 and conforming to BS2869, Class A2)

Air Systems	50 Hz	60 Hz
Air Filter Type:	Replaceable Element	
Combustion Air Flow: m ³ /min (cfm)		
- Prime	1.5 (51)	1.7 (61)
- Standby	1.5 (51)	1.7 (61)
Max. Combustion Air Intake Restriction: kPa (in H ₂ O)	3.0 (12.0)	3.0 (12.0)

Cooling System	50 Hz	60 Hz
Cooling System Capacity: l (US gal)	6.5 (1.7)	6.5 (1.7)
Water Pump Type:	Centrifugal	
Heat Rejected to Water & Lube Oil:		
kW (Btu/min)		
- Prime	19.6 (1115)	22.2 (1262)
- Standby	21.6 (1228)	24.2 (1376)
Heat Radiation to Room: Heat radiated from engine and alternator		
kW (Btu/min)		
- Prime	5.8 (330)	6.6 (375)
- Standby	7.0 (398)	8.0 (455)
Radiator Fan Load: kW (hp)	0.2 (0.3)	0.4 (0.5)
Radiator Cooling Airflow: m ³ /min (cfm)	33.0 (1165)	41.4 (1462)
External Restriction to Cooling Airflow: Pa (in H ₂ O)	125 (0.5)	125 (0.5)

Contact your local FG Wilson Dealer for power ratings at specific site conditions.

Lubrication System	
Oil Filter Type:	Spin-On, Full Flow
Total Oil Capacity: l (US gal)	10.6 (2.8)
Oil Pan: l (US gal)	8.9 (2.4)
Oil Type:	API CH4 15W-40
Oil Cooling Method:	N/A

Exhaust System	50 Hz	60 Hz
Silencer Type:	Industrial	
Silencer Model & Quantity:	263-0765 (1)	
Pressure Drop Across Silencer System: kPa (in Hg)	0.70 (0.207)	1.60 (0.472)
Silencer Noise Reduction Level: dB	28	21
Maximum Allowable Back Pressure: kPa (in Hg)	10.0 (3.0)	10.0 (3.0)
Exhaust Gas Flow: m ³ /min (cfm)		
- Prime	3.8 (134)	4.3 (153)
- Standby	4.2 (148)	4.8 (168)
Exhaust Gas Temperature: °C (°F)		
- Prime	410 (770)	440 (824)
- Standby	451 (844)	510 (950)

Alternator Physical Data	
Manufactured for FG Wilson by:	Leroy Somer
Model:	LLB1014N
No. of Bearings:	1
Insulation Class:	H
Winding Pitch Code:	2/3 - M
Wires:	4
Ingress Protection Rating:	IP23
Excitation System:	SHUNT
AVR Model:	R250

Alternator Operating Data	
Overspeed: rpm	2250
Voltage Regulation: (Steady state)	+/- 1.0
Wave Form NEMA = TIF:	50
Wave Form IEC = THF:	2.0%
Total Harmonic content LL/LN:	4.0%
Radio Interference:	Suppression is in line with European Standard EN61000-6
Radiant Heat: kW (Btu/min)	
- 50 Hz	2.6 (148)
- 60 Hz	3.4 (193)

Alternator Performance Data:	50 Hz			60 Hz	
	240V	230V	220V	220V/110V	240V/120V
Data Item					
Motor Starting Capability* kVA	33	31	29	25	29
Short Circuit Capacity** %	-	-	-	-	-
Reactances: Per Unit					
Xd	1.370	1.490	1.630	2.340	1.970
X'd	0.180	0.200	0.220	0.310	0.260
X''d	0.086	0.094	0.102	0.147	0.124

Reactances shown are applicable to prime ratings.
 *Based on 30% voltage dip at 0.9 power factor.
 **With optional permanent magnet generator or SHUNT excitation.

Voltage Technical Data 50 Hz				
Voltage	Prime:		Standby:	
	kVA	kW	kVA	kW
240V	15.0	15.0	16.5	16.5
230V	15.0	15.0	16.5	16.5
220V	15.0	15.0	16.5	16.5

Voltage Technical Data 60 Hz				
Voltage	Prime:		Standby:	
	kVA	kW	kVA	kW
220V/110V	18.0	18.0	20.0	20.0
240V/120V	18.0	18.0	20.0	20.0

Documentation

A full set of operation and maintenance manuals and circuit wiring diagrams.

Generating Set Standards

The equipment meets the following standards: BS5000, ISO 8528, ISO 3046, IEC 60034, NEMA MG-1.22.

FG Wilson is a fully accredited ISO 9001 company.

EU Stage II Emissions Compliant.

Warranty

All prime equipment carries a one year manufacturer's warranty. Standby equipment, limited to 500 running hours per year, has a two year manufacturer's warranty. For details on warranty cover please contact your local Dealer, or visit our website: FGWilson.com.

Dealer contact details:

FG Wilson has manufacturing facilities in the following locations:

Northern Ireland • Brazil • China • India • USA

With headquarters in Northern Ireland, FG Wilson operates through a Global Dealer Network.

To contact your local Sales Office please visit the FG Wilson website at www.FGWilson.com